



Display Specification

WWW.LCDSOLAR.COM

Solar Technologies, Inc. – Headquarters
26180 Enterprise Way
Building No. 100
Lake Forest, CA 92630

949.458.1080 Tel.
949.458.1081 Fax
Sales@LCDSolar.com

The Solar Technologies name and logo are the registered service marks of Solar Technologies, Inc. All other trademarks, service marks, logos, slogans, domain names, trade names and copyrights (collectively "Marks") are the properties of their respective owners. Solar Technologies disclaims any proprietary interest in Marks other than its own. All product specifications are provided for convenience only. The product specifications contained herein are provided "as is" and with respect to the information contained therein Solar Technologies disclaims all representations and warranties of any kind, including warranties of merchantability, fitness for a particular purpose, and accuracy of the content. Please consult the manufacturer for specific product information.

Version :1.3

TECHNICAL SPECIFICATION

MODEL NO. : PD035VX2

Customer's Confirmation

Customer _____

By _____

PVI's Confirmation

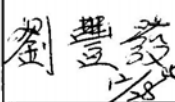
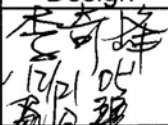
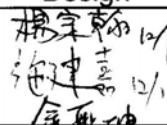
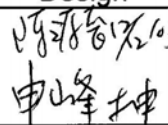
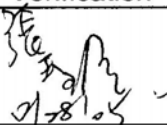
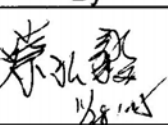
Dep	FAE	Panel Design	Electronic Design	Mechanical Design	Product Verification	Prepared By
Sign						

TECHNICAL SPECIFICATION

CONTENTS

<i>NO.</i>	<i>ITEM</i>	<i>PAGE</i>
-	Cover	1
-	Contents	2
1	Application	3
2	Features	3
3	Mechanical Specifications	3
4	Mechanical Drawing of TFT-LCD module	4
5	Input / Output Terminals	5
6	Absolute Maximum Ratings	7
7	Electrical Characteristics	7
8	Pixel Arrangement	9
9	Display Color and Gray Scale Reference	10
10	Block Diagram	11
11	Interface Timing	12
12	Power On Sequence	17
13	Optical Characteristics	17
14	Handling Cautions	21
15	Reliability Test	22
16	Packing	23
-	Revision History	25
-	Appendix	26

1. Application

This data sheet applies to a color TFT LCD module , PD035VX2. PD035VX2 module applies to projector , and other media application which require high quality flat panel display.

2. Features

- . Amorphous silicon TFT LCD panel
- . Pixel in stripe configuration
- . Display Colors : 262,144 colors
- . Optimum Viewing Direction : 6 o'clock
- . TTL transmission interface

3. Mechanical Specifications

Parameter	Specifications	Unit
Screen Size	3.5 (diagonal)	inch
Display Format	640×(R, G, B)×480	dot
Display Colors	262,144	
Active Area	72 (H)×52.56 (V)	mm
Pixel Pitch	0.1125 (H)×0.1095 (V)	mm
Pixel Configuration	Stripe	
Outline Dimension	84.03 (W)×65.24 (H)×3.45 (D) (Typ.)	mm
Weight	40±5	g
Surface treatment	AG	
Display mode	Normally white	

4.Mechanical Drawing of TFT-LCD Module

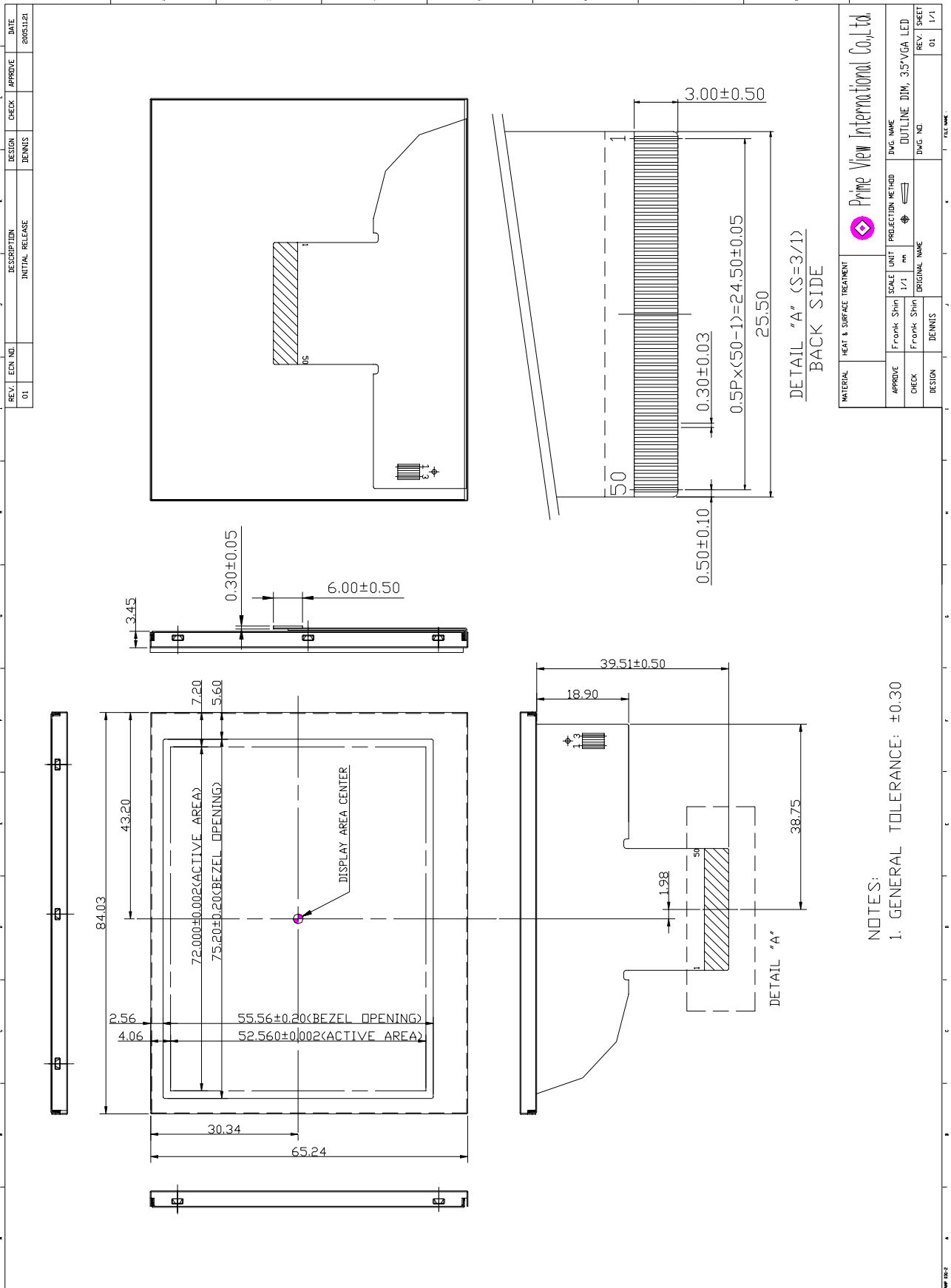

5.Input / Output Terminals
TFT-LCD Panel Driving

Pin No.	Symbol	I/O	Function	Remark
1	DIO1	I/O	Horizontal Start Pulse Signal Input or Output 1	Note5-3
2	VSS2	I	Ground	
3	VDD1	I	Power Supply	
4	CLK	I	Horizontal Shift Clock	
5	R/L	I	Left/Right Selection	Note 5-3
6	R0	I	Red Data (LSB)	
7	R1	I	Red Data	
8	R2	I	Red Data	
9	R3	I	Red Data	
10	R4	I	Red Data	
11	R5	I	Red Data (MSB)	
12	VSS2	I	Ground	
13	G0	I	Green Data (LSB)	
14	G1	I	Green Data	
15	G2	I	Green Data	
16	G3	I	Green Data	
17	G4	I	Green Data	
18	G5	I	Green Data (MSB)	
19	B0	I	Blue Data (LSB)	
20	B1	I	Blue Data	
21	B2	I	Blue Data	
22	B3	I	Blue Data	
23	B4	I	Blue Data	
24	B5	I	Blue Data (MSB)	
25	LD	I	Load output signal	Note5-7
26	REV	I	Data invert control	Note5-8
27	POL	I	Polarity selection	Note5-9
28	DIO2	I/O	Horizontal Start Pulse Signal Input or Output	Note5-3
29	VSS2	I	Ground	
30	V3	I	Gamma Voltage 3	Note5-10
31	V5	I	Gamma Voltage 5	Note5-10
32	V7	I	Gamma Voltage 7	Note5-10
33	V8	I	Gamma Voltage 8	Note5-10
34	V10	I	Gamma Voltage 10	Note5-10
35	V12	I	Gamma Voltage 12	Note5-10
36	VSS2	I	Ground	
37	VDD2	I	Voltage for analog circuit	Note5-10
38	VCOM	I	Common Voltage	
39	OE	I	Output Enable	Note5-5
40	U/D	I	Up/Down Selection	Note5-6
41	CKV	I	Vertical Shift Clock	Note5-4
42	STVU	I/O	Vertical Shift Pulse Signal Input or Output	Note5-6
43	STVD	I/O	Vertical Shift Pulse Signal Input or Output	Note5-6
44	VGG	I	Gate On Voltage	Note5-1
45	VSS1	I	Ground	
46	VCC	I	Voltage for logic circuit	
47	VEE	I	Gate Off Voltage	Note5-2
48	VLED	-	Supply voltage for LED backlight	Note5-11
49	GLED2	-	Ground for LED backlight	
50	GLED1	-	Ground for LED backlight	

Note 5-1 $V_{GG} = +17V$.

Note 5-2 $V_{EE} = -10V$.

Note 5-3: Select left or right shift

R/L	DIO1	DIO2	Shift
1	Input	Hi-Z	Left to right
0	Hi-Z	Input	Right to left

Note 5-4: Gate driver shift clock

Note 5-5: When OE is connected to high “1”, the driver outputs are disabled (Gate output = V_{EE}).
Under this condition, the operation of registers will not be affected.

Note 5-6: Select up or down shift

U/D	STVU	STVD	Shift
1	Hi-Z	Input	Down to Up
0	Input	Hi-Z	Up to Down

Note 5-7 Latch the polarity of outputs and switch the new data to outputs

At the rising edge (LD), latch the “POL” signal to control the polarity of the outputs.

Note 5-8 Control whether the Data R0~G5 are inverted or not. (PVI suggests connecting to GND)

When “REV=1”, these data will be inverted.

EX: “00” ”3F”, “07” ”38”, “15” ”2A”

Note 5-9: Polarity selector for dot-inversion control. Available at the rising edge of LD.

When POL=1: Even outputs range from V1~V7, and Odd outputs range from V8~V14;

When POL=0: Even outputs range from V8~V14, and Odd outputs range from V1~V7.

Note 5-10

Typical Application Circuit

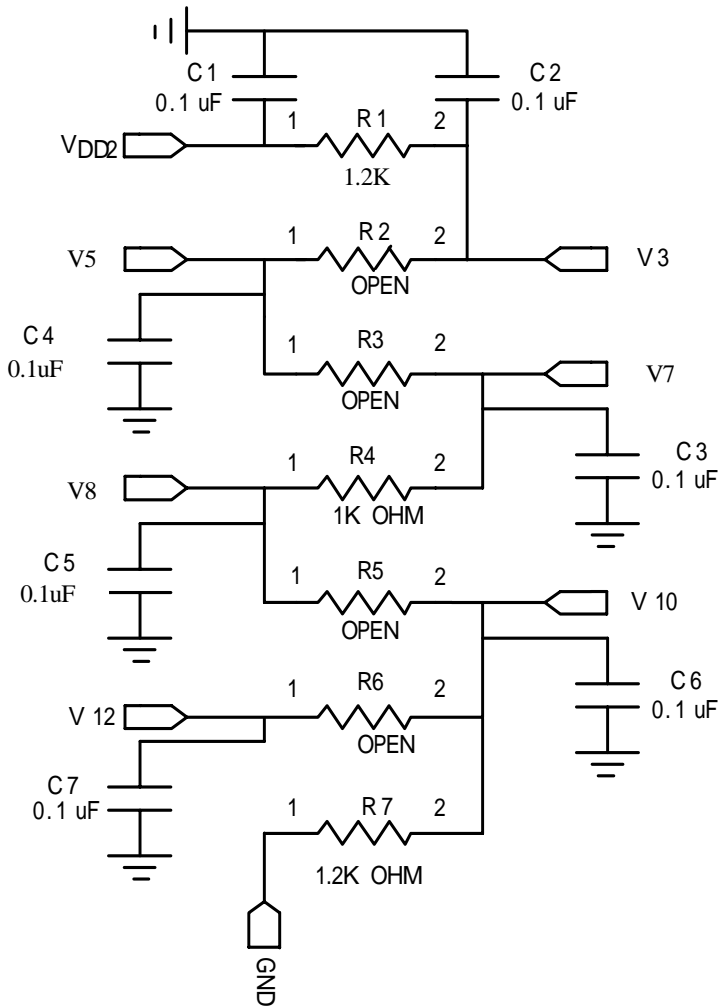

Note 5-11: I_{LED} TYP.=20mA.

6.Absolute Maximum Ratings:

V_{SS1}=V_{SS2}=GND=0V, Ta=25

Parameters	Symbol	MIN.	MAX.	Unit	Remark
Supply Voltage	V _{DD1}	-0.5	5.0	V	
	V _{CC}	-0.3	5.0	V	
	V _{DD2}	-0.5	12.0	V	
	V _{GG}	-0.3	40.0	V	
	V _{GG} - V _{EE}	-	40.0	V	
	V _{EE}	-20	0.3	V	

7.Electrical Characteristics

7-1) Recommended Operating Conditions:

V_{SS1}=V_{SS2}=GND = 0V , Ta = 25

Item	Symbol	Min.	Typ.	Max.	Unit	Remark
Supply Voltage for Source Driver	V _{DD1}	3.0	3.3	3.6	V	
	V _{DD2}	9.5	10	10.5		
Supply Voltage for Gate Driver	V _{GG}	-	17	-	V	
	V _{EE}	-	-10	-	V	
	V _{CC}	3.0	3.3	3.6	V	
Digital Input Voltage	V _{IH}	0.8V _{DD1}	-	V _{DD1}	V	
	V _{IL}	0	-	0.2V _{DD1}	V	

7-2) Recommended driving condition for LED backlight

GND = 0 V , Ta = 25

Parameter	Symbol	Min	TYP	MAX	Unit	Remark
Supply voltage of LED backlight	V _{LED}	9	9.6	11.4	V	I _L = 20 mA
Supply current of LED backlight	I _{LED1}	-	20	-	mA	Note 7-1
	I _{LED2}					
Backlight Power Consumption	P _{LED}	360	384	456	mW	Note 7-2

Note 7-1 : LED B/L applied information , please refer to the appendix at the end .

Note 7-2 : P_{LED} = V_{LED} * I_{LED1} + V_{LED} * I_{LED2} .

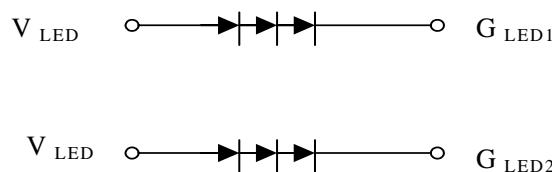

7-3) Power Consumption

Parameter	Symbol	Condition	Typ.	Max.	Unit	Remark
Supply Current for Gate Driver (Hi level)	I_{GG}	$V_{GG}=+17V$	0.12	0.15	mA	
Supply Current for Gate Driver (Low level)	I_{EE}	$V_{EE}=-10V$	0.15	0.19	mA	
Supply Current for Source Driver (Digital)	I_{DD1}	$V_{DD1}=+3.3V$	4.8	8.0	mA	
Supply Current for Source Driver (Analog)	I_{DD2}	$V_{DD2}=+10V$	16.0	30.0	mA	
Supply Current for Gate Driver (Digital)	I_{CC}	$V_{CC}=+3.3V$	0.17	0.21	mA	
LCD Panel Power Consumption	-	-	180	332	mW	
Backlight Power Consumption	P_{LED}	-	384	456	mW	
Total Power Consumption	-	-	564	788	mW	

8. Pixel Arrangement

The LCD module pixel arrangement is the stripe.

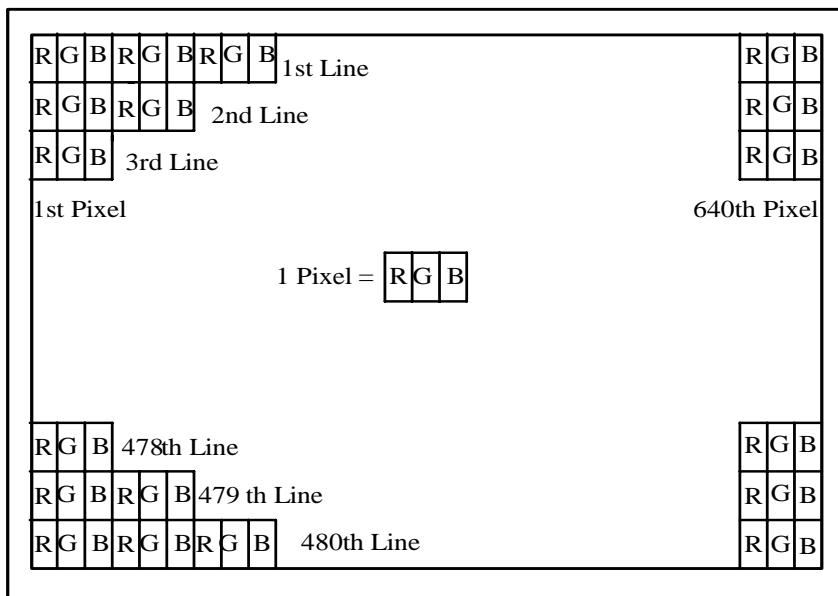

9. Display Color and Gray Scale Reference

Color		Input Color Data																	
		Red						Green						Blue					
		R5	R4	R3	R2	R1	R0	G5	G4	G3	G2	G1	G0	B5	B4	B3	B2	B1	B0
Basic Colors	Black	0	0	0	0	0	0	0	0	0	0	0	0	0	0	0	0	0	0
	Red (63)	1	1	1	1	1	1	0	0	0	0	0	0	0	0	0	0	0	0
	Green (63)	0	0	0	0	0	0	1	1	1	1	1	1	0	0	0	0	0	0
	Blue (63)	0	0	0	0	0	0	0	0	0	0	0	0	1	1	1	1	1	1
	Cyan	0	0	0	0	0	0	1	1	1	1	1	1	1	1	1	1	1	1
	Magenta	1	1	1	1	1	1	0	0	0	0	0	0	1	1	1	1	1	1
	Yellow	1	1	1	1	1	1	1	1	1	1	1	1	0	0	0	0	0	0
	White	1	1	1	1	1	1	1	1	1	1	1	1	1	1	1	1	1	1
Red	Red (00)	0	0	0	0	0	0	0	0	0	0	0	0	0	0	0	0	0	0
	Red (01)	0	0	0	0	0	1	0	0	0	0	0	0	0	0	0	0	0	0
	Red (02)	0	0	0	0	1	0	0	0	0	0	0	0	0	0	0	0	0	0
	Darker																		
	Brighter																		
	Red (61)	1	1	1	1	0	1	0	0	0	0	0	0	0	0	0	0	0	0
	Red (62)	1	1	1	1	1	0	0	0	0	0	0	0	0	0	0	0	0	0
	Red (63)	1	1	1	1	1	1	0	0	0	0	0	0	0	0	0	0	0	0
Green	Green (00)	0	0	0	0	0	0	0	0	0	0	0	0	0	0	0	0	0	0
	Green (01)	0	0	0	0	0	0	0	0	0	0	0	1	0	0	0	0	0	0
	Green (02)	0	0	0	0	0	0	0	0	0	0	1	0	0	0	0	0	0	0
	Darker																		
	Brighter																		
	Green (61)	0	0	0	0	0	0	1	1	1	1	0	1	0	0	0	0	0	0
	Green (62)	0	0	0	0	0	0	1	1	1	1	1	0	0	0	0	0	0	0
	Green (63)	0	0	0	0	0	0	1	1	1	1	1	1	0	0	0	0	0	0
Blue	Blue (00)	0	0	0	0	0	0	0	0	0	0	0	0	0	0	0	0	0	0
	Blue (01)	0	0	0	0	0	0	0	0	0	0	0	0	0	0	0	0	0	1
	Blue (02)	0	0	0	0	0	0	0	0	0	0	0	0	0	0	0	0	1	0
	Darker																		
	Brighter																		
	Blue (61)	0	0	0	0	0	0	0	0	0	0	0	0	1	1	1	1	0	1
	Blue (62)	0	0	0	0	0	0	0	0	0	0	0	0	1	1	1	1	1	0
	Blue (63)	0	0	0	0	0	0	0	0	0	0	0	0	1	1	1	1	1	1

10. Block Diagram

10-1) TFT-module Block Diagram

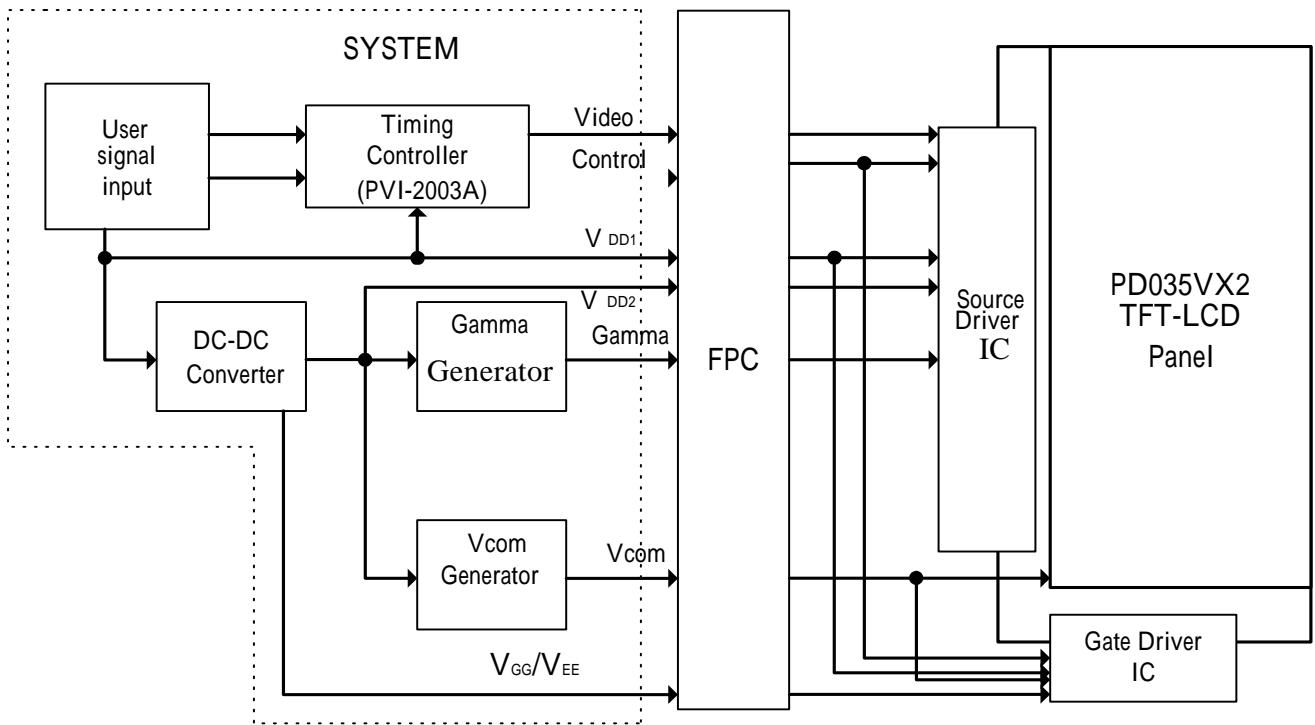

If you use PD035VX2, you must apply PVI-2003A(Timing controller) which Will generate signal to support PD035VX2.

11. Interface Timing

11.1) Timing Parameters

AC Electrical Characteristics ($V_{CC}=V_{DD1}=3.3V$, $V_{DD2}=10V$, $GND=V_{SS1}=V_{SS2}=0V$, $T_a=25$)

Parameter	Symbol	Min.	Typ.	Max.	Unit
CLK Frequency	Fclk	-	25	40	MHz
CLK Pulse Width	T _{CPH}	25	40	-	ns
Data Set-up Time	T _{su}	4	-	-	ns
Data Hold Time	T _{hd}	2	-	-	ns
Propagation Delay of DIO2/1	T _{phl}	6	10	15	ns
Time That The Last Data to LD	T _{ld}	1	-	-	T _{CPH}
Pulse width of LD	T _{wld}	2	-	-	T _{CPH}
Time That LD to DIO1/2	T _{lds}	5	-	-	T _{CPH}
POL Set-up Time	T _{psu}	6	-	-	ns
POL Hold Time	T _{phd}	6	-	-	ns
OE Pulse Width	T _{OEV}	1	-	-	μs
CKV Pulse Width	T _{CKV}	500	-	-	ns
STV Set-up Time	T _{SUV}	400	-	-	ns
STV Hold Time	T _{HDV}	400	-	-	ns
Horizontal Display Period	T _{HDP}	-	640	-	T _{CPH}
Horizontal Period Timing Range	T _{HP}	-	800	-	T _{CPH}
Horizontal Lines Per Field	T _V	520	525	640	T _{HP}
Vertical Display Timing Range	T _{DV}	-	480	-	T _{HP}

11.2) Timing Diagram

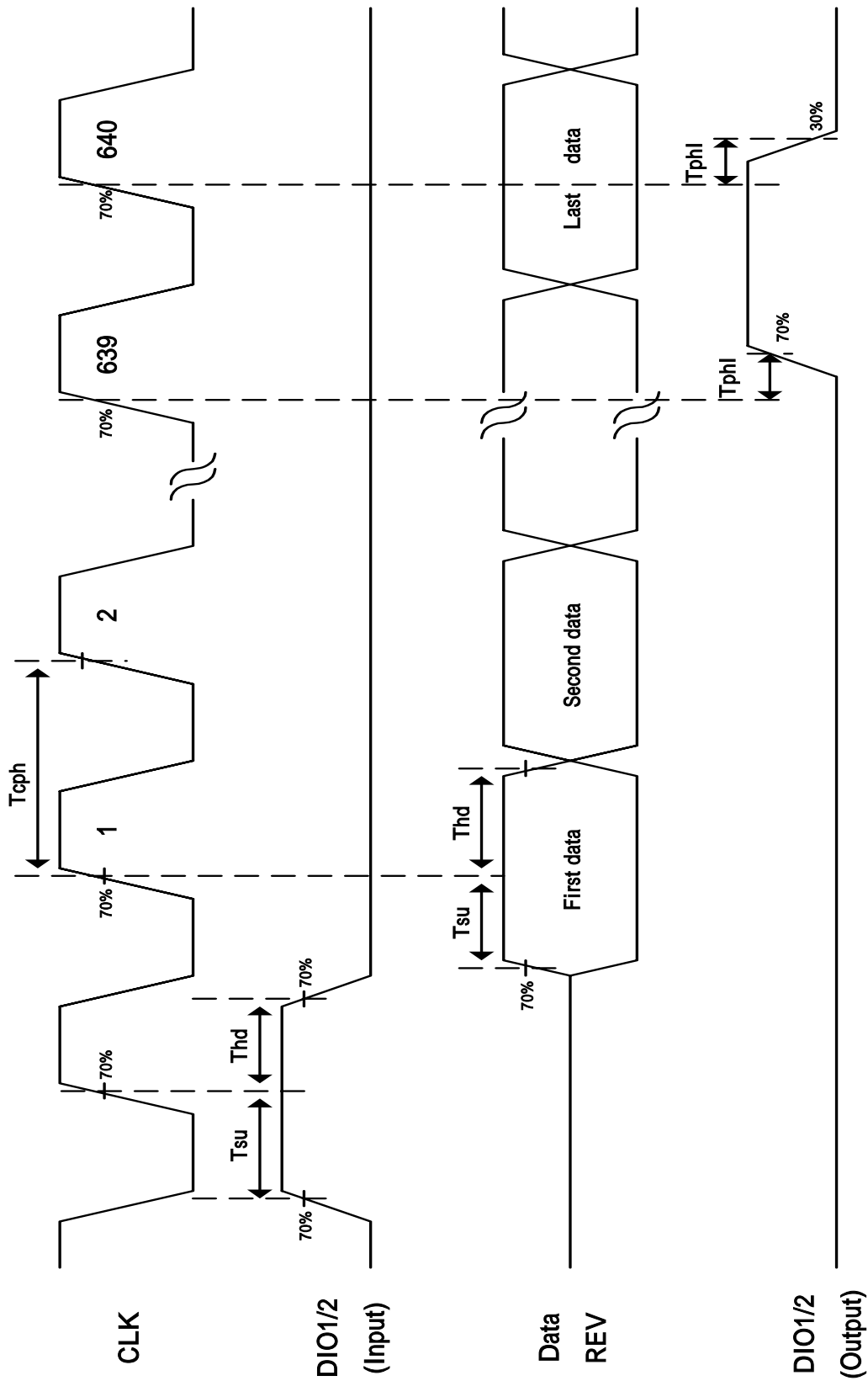

Fig. 11-1 Horizontal timing(1)

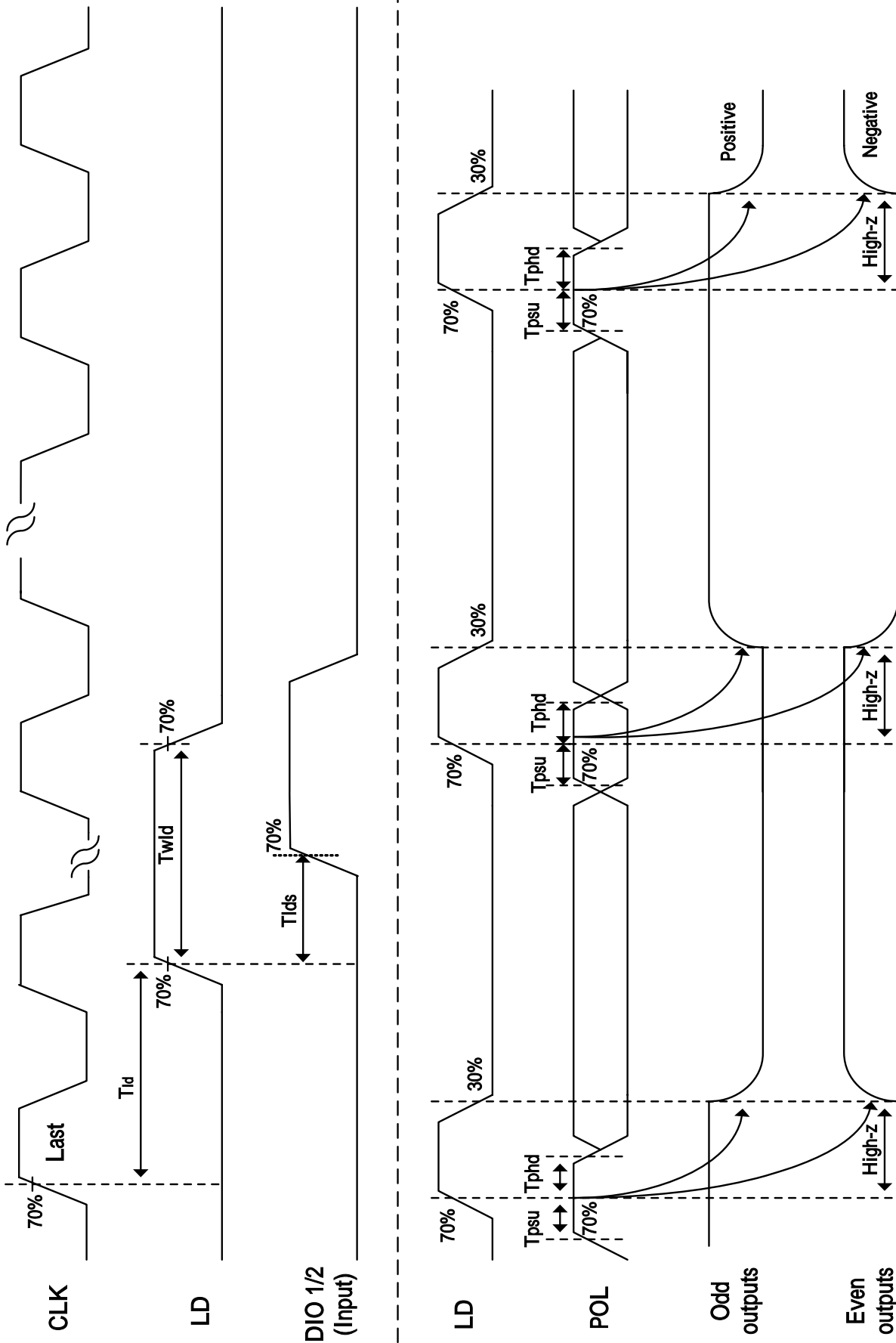

Fig. 11-2 Horizontal timing(2)

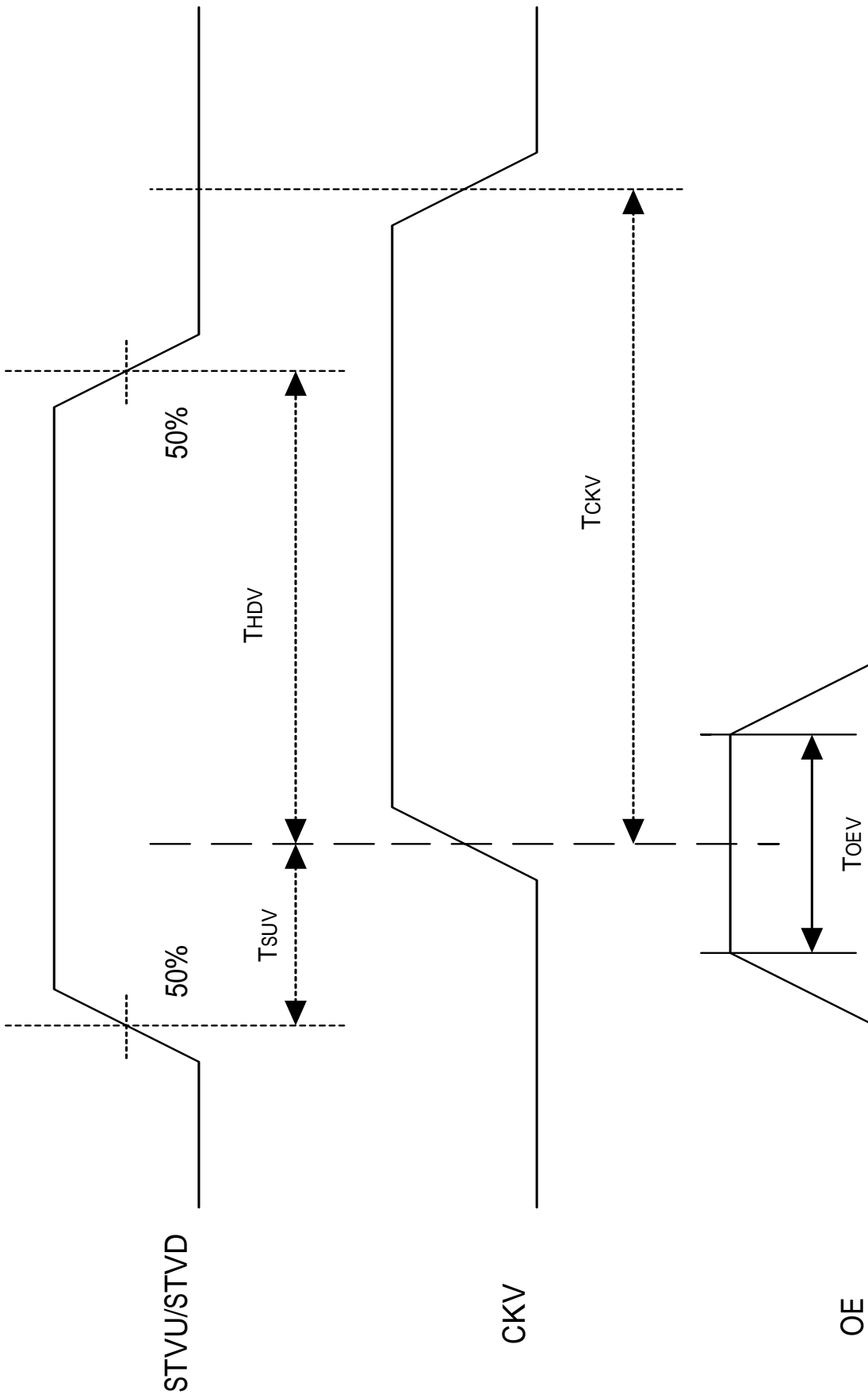

Fig. 11-3 Vertical shift clock timing

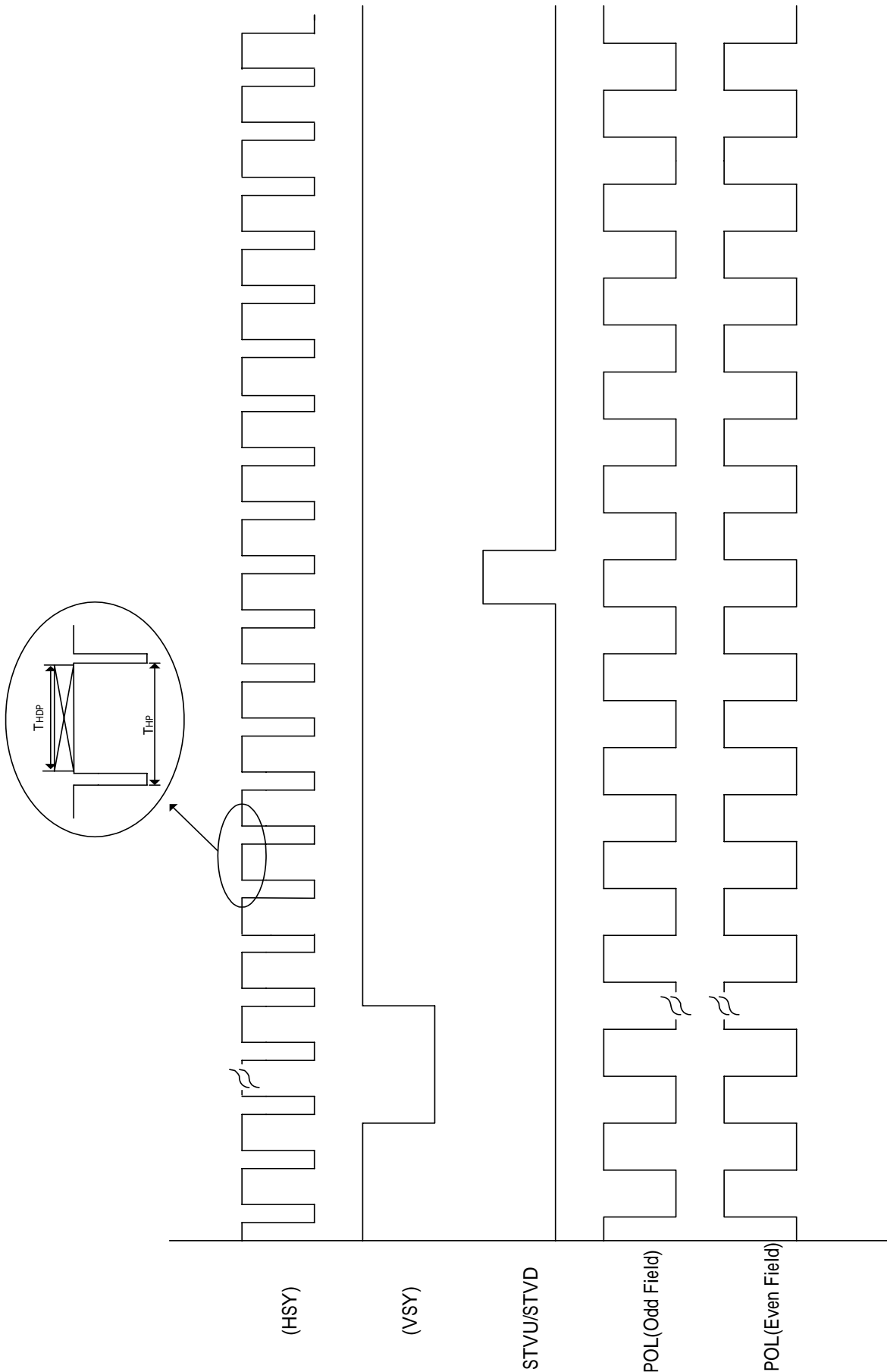
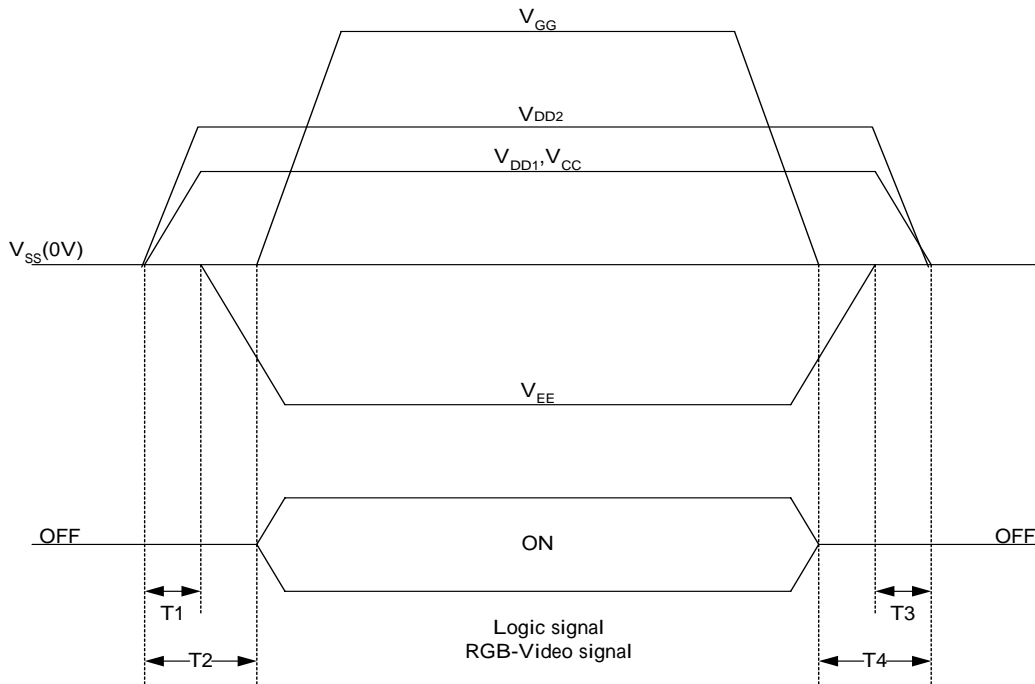

Fig. 11-4 Vertical timing

12. Power On Sequence



- 1) 10ms $T1 < T2$
- 2) 0ms $< T3 < T4 < 10ms$

13. Optical Characteristics

13-1) Specification:

$T_a=25$

Parameter	Symbol	Condition	MIN.	TYP.	MAX.	Unit	Remarks
Viewing Angle	Horizontal	21, 22	± 45	± 50	-	deg	Note 13-2
	Vertical	12 (to 12 o'clock)	10	15	-	deg	
		11 (to 6 o'clock)	30	35	-	deg	
Contrast Ratio	CR	-	200	400	-	-	Note 13-4
Response time	Rise	T_r	-	15	30	ms	Note 13-3
	Fall	T_f	-	25	50	ms	
Brightness	L	$=0^\circ$	200	250	-	cd/m^2	Note 13-1
Uniformity	U	$=0^\circ$	70	75	-	%	Note 13-5
Cross Talk	-	$=0^\circ$	-	-	3	%	Note 13-6
White Chromaticity	x	-	0.28	0.310	0.34	-	Note 13-1
	y	-	0.30	0.330	0.36	-	
LED Life Time	-	$T_a=25$	-	10000	-	hrs	

All the optical measurement shall be executed 1 minute after backlight being turn-on. The optical characteristics shall be measured in dark room (ambient illumination on panel surface less than 1 Lux). The measuring configuration shows as following figure.

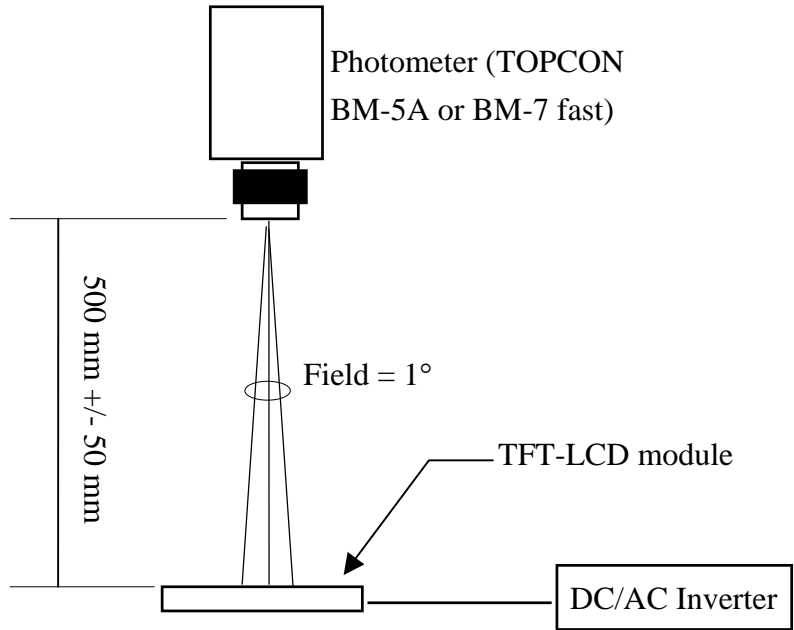

Optical characteristics measuring configuration

Note 13-1: 1.Topcon BM-5A or BM-7 fast luminance meter 1° field of view is used in the testing (after 1 minute operation).

Note 13-2: The definitions of viewing angles are as follow

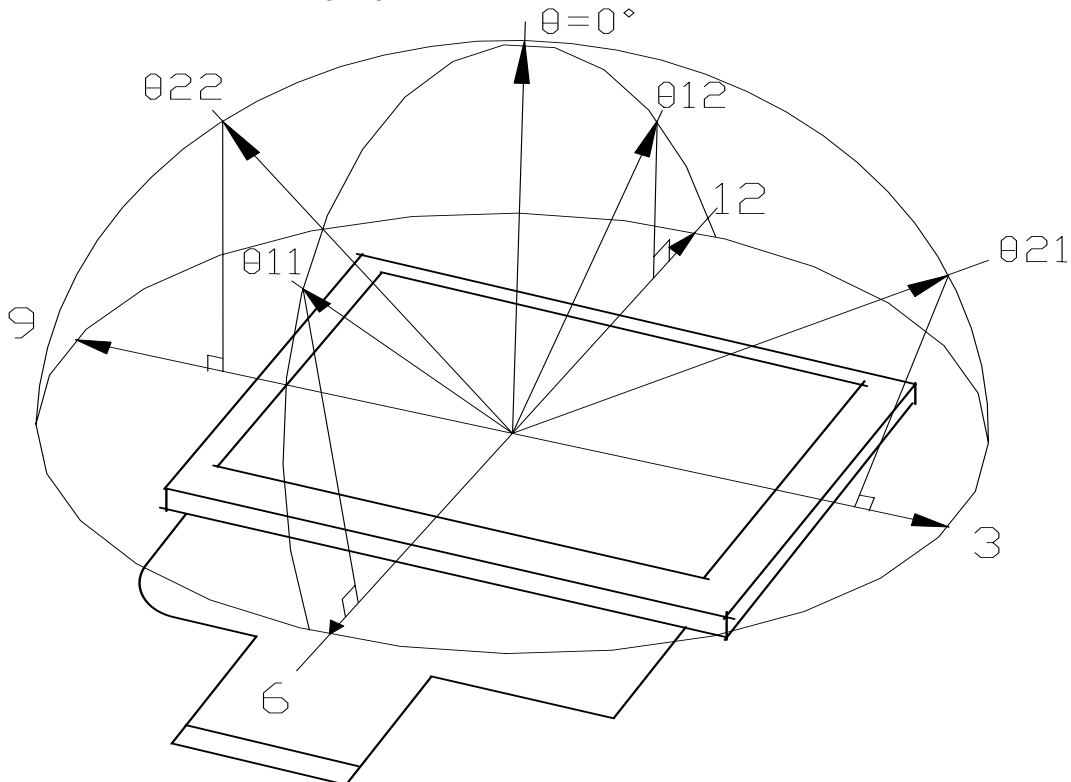

Note 13-3: Definition of Response Time T_r and T_f :

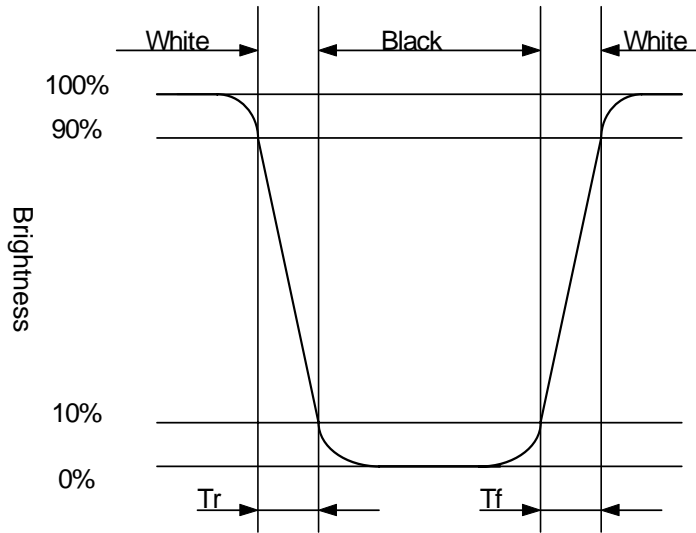

Note 13-4: The definition of contrast ratio $CR = \frac{\text{Luminance at gray level 63}}{\text{Luminance at gray level 0}}$

Note 13-5 : The uniformity of LCD is defined as

$$U = \frac{\text{The Minimum Brightness of the 9 testing Points}}{\text{The Maximum Brightness of the 9 testing Points}}$$

Luminance meter : BM-5A or BM-7 fast (TOPCON)

Measurement distance : 500 mm +/- 50 mm

Ambient illumination : < 1 Lux

Measuring direction : Perpendicular to the surface of module

The test pattern is white (Gray Level 63).

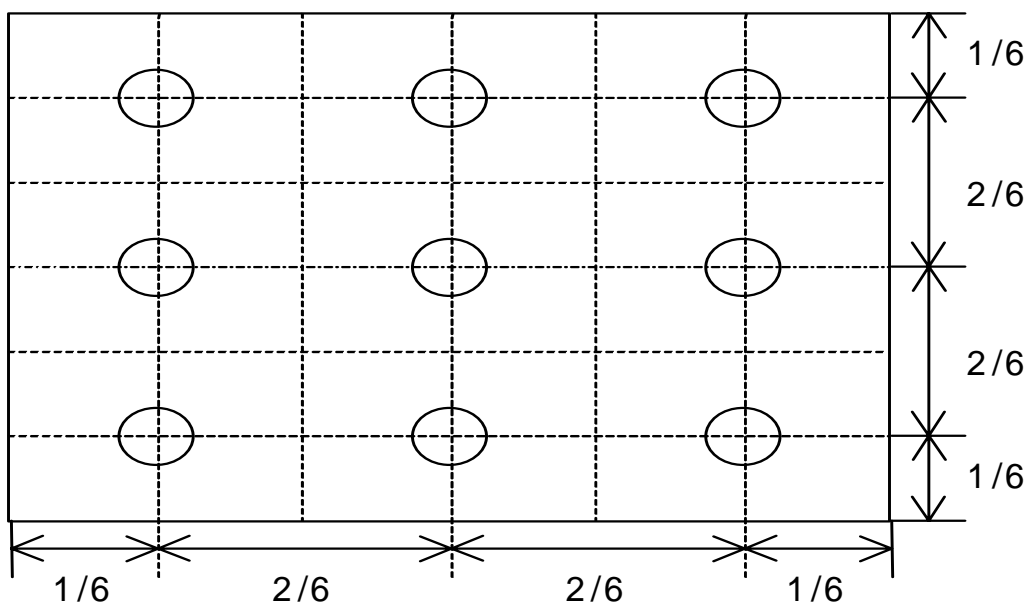

Note 13-6 : Cross Talk (CTK) = $\frac{|Y_A - Y_B|}{Y_A} \times 100\%$

Y_A : Brightness of Pattern A

Y_B : Brightness of Pattern B

Pattern A

(Gray Level 31)

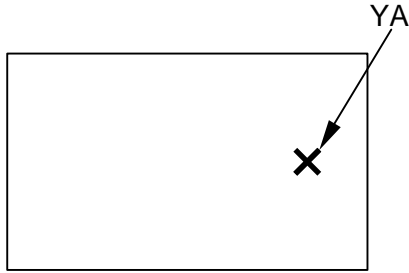

Pattern B

(Gray Level 31, central black box exclusive)

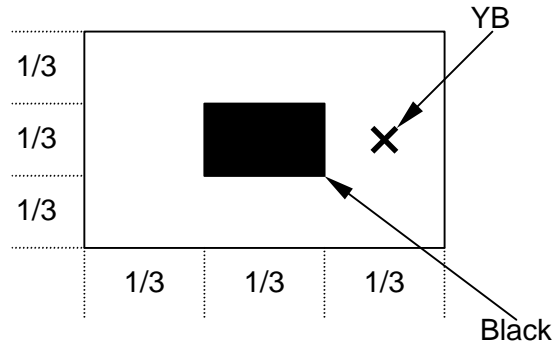

X: Testing Point (A and B are at the same point.)

Black (Gray Level 0)

14. Handling Cautions

14-1) Mounting of module

- a) Please power off the module when you connect the input/output connector.
- b) Polarizer which is made of soft material and susceptible to flaw must be handled carefully.
- c) Protective film (Laminator) is applied on surface to protect it against scratches and dirt. It is recommended to peel off the laminator before use and taking care of static electricity.

14-2) Precautions in mounting

- a) Wipe off water drops or finger grease immediately. Long contact with water may cause discoloration or spots.
- b) TFT-LCD module uses glass which breaks or cracks easily if dropped or bumped on hard surface. Please handle with care.
- c) Since CMOS LSI is used in the module. So take care of static electricity and earth yourself when handling.

14-3) Others

- a) Do not expose the module to direct sunlight or intensive ultraviolet rays for many hours.
- b) Store the module at a room temperature place.
- c) The voltage of beginning electric discharge may over the normal voltage because of leakage current from approach conductor by to draw lump read lead line around.
- d) If LCD panel breaks, it is possibly that the liquid crystal escapes from the panel. Avoid putting it into eyes or mouth. When liquid crystal sticks on hands, clothes or feet. Wash it out immediately with soap.
- e) Observe all other precautionary requirements in handling general electronic components.

15. Reliability Test

No	Test Item	Test Condition
1	High Temperature Storage Test	Ta = +70 , 240 hrs
2	Low Temperature Storage Test	Ta = -20 , 240 hrs
3	Low Temperature Operation Test	Ta = -20 , 240 hrs
4	High Temperature Operation Test	Ta = +70 , 240 hrs
5	High Temperature & High Humidity Operation Test	Ta = +60 , 90%RH, 240 hrs (No Condensation)
6	Thermal Cycling Test (non-operating)	-20 → +70 , 200 Cycles 30min 30min
7	Vibration Test (non-operating)	Frequency : 10 ~ 55 Hz Amplitude : 1.0 mm Sweep time : 11 mins Test Period : 6 Cycles for each direction of X, Y, Z
8	Shock Test (non-operating)	100G , 6ms Direction : ±X , ±Y , ±Z Cycle : 3 times
9	Electrostatic Discharge Test (non-operating)	200pF, 0 ±200V 1 time / each terminal

Ta: ambient temperature

Note : The protective film must be removed before temperature test.

[Criteria]

1. Main LCD should normally work under the normally condition no defect of function, screen quality and appearance (including : mura , line defect , no image)
2. After the temperature and humidity test, the luminance and CR (Contrast ratio) , should not be lower than minimum of specification
3. After the vibration and shock test , can't be find chip , broken

16. Packing

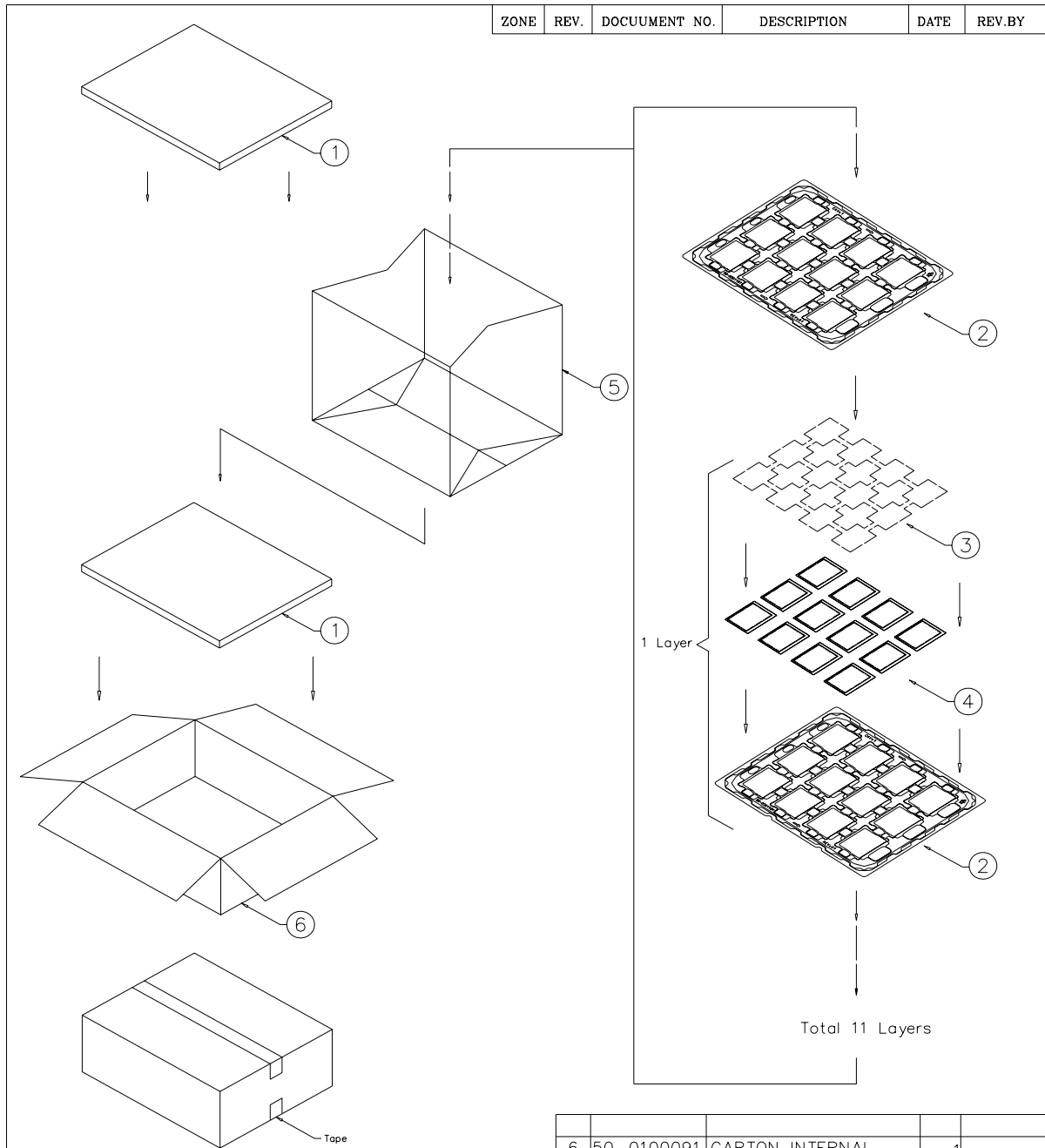

NOTE:

1. One layer include: 1 piece of cushion sheet, 12pcs panel & 1 piece of tray.
2. Q'TY: 120 pcs panel/carton.
3. Dimension: 455*375*190mm
4. Weight: 7.7 KG

6	50-0100091	CARTON INTERNAL	1	
5	50-0500041	摺口袋450*380*700mm	1	抗靜電
4		PD035VX2	120	
3	50-0200059	EPE CUSHION SHEET	10	抗靜電
2	50-0301181	TRAY	11	抗靜電
1	50-0300491	EPE FOAM	2	
ITEM	PART NO.	DESCRIPTION	QTY	REMARK

MTL.SPEC.		UNSPECIFIED TOL'S ±5.0mm		REMARK		元太科技股份有限公司 Prime View Internation Co.,ltd.	
		ANGLE					
		ROUGHNESS					
APPROVE	Frank Shin	'05.01.21	SCALE	UNIT	SHEET	DWG.TITLE	
CHECK	Frank Shin	'05.01.21	1:1	mm	1 OF 2	PD035VX2 PACKING Dim	
DESIGN	Dennis	'05.01.21	MTL.NO.		DWG.NO.		REV. 02
							A ₄ SIZE

ZONE	REV.	DOCUMENT NO.	DESCRIPTION	DATE	REV. BY
------	------	--------------	-------------	------	---------

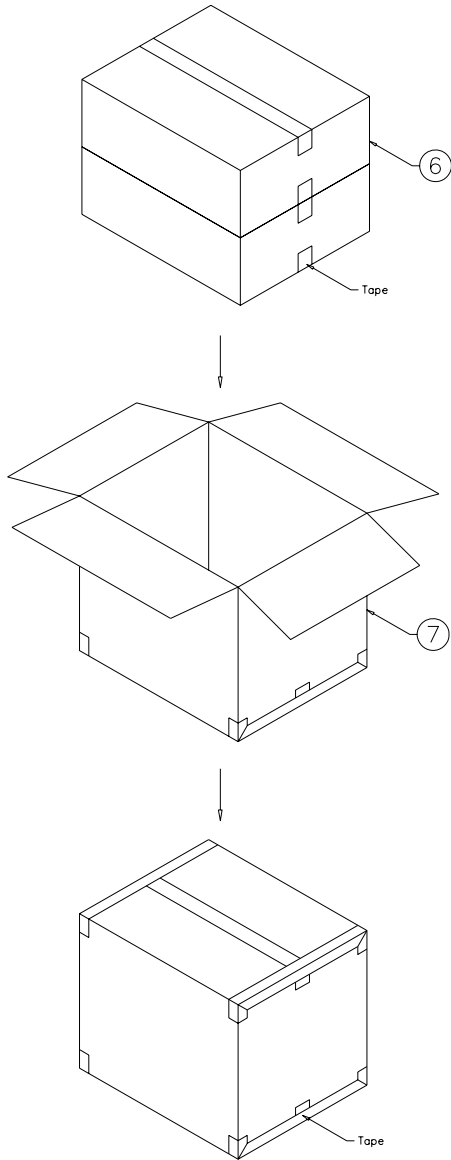

NOTE:

1. Q'TY: 240 pcs panel/carton.
2. Dimension: 480*396*405mm
3. Weight: 16.3 KG

ITEM	PART NO.	DESCRIPTION	QTY	REMARK
7	50-0100101	CARTON EXTERNAL	1	

MTL.SPEC.		UNSPECIFIED TOL'S ±5.0mm		REMARK		元太科技股份有限公司 Prime View International Co.,Ltd.		
		ANGLE						
		ROUGHNESS						
APPROVE	Frank Shin	'05.01.21	SCALE	UNIT	SHEET	DWG.TITLE		
CHECK	Frank Shin	'05.01.21	1:1	mm	2 OF 2	PD035VX2 PACKING Dim		
DESIGN	Dennis	'05.01.21	MTL.NO.			DWG.NO.	REV. 02	A ₄ SIZE

Revision History

Rev.	Issued Date	Revised Contents
0.1	Oct. 21 , 2004	New
1.0	Jan. 26 , 2005	Removed Page 24 : Indication of Lot Number Label Add Page 24 : Reliability (Note : The protective film must be removed before temperature test.)
1.1	Apr. 20, 2005	Modify: Page 10 : Absolute Maximum Ratings-Operation Temperature range Page 24 : Reliability Test Condition 1. Add High Temperature Operation Test +70 . 2. Change Low Temperature Operation Test Condition from 0 to -20 .
1.2	Sep. 29, 2005	Page 9 3) Typical Application Circuit Modify resistance in Circuit Before modify: R1=2.5K, R7=51K After modify: R1=1.2K,R7=1.2K
1.3	Nov.28, 2005	Page 8 6.Absolute Maximum Ratings: before modify: VDD1 =2V,min.=-0.3V After modify: VDD1 =5V,min.=-0.5V

Appendix

